

TOSHIBA

AIR CONDITIONER (SPLIT TYPE) Owner's Manual

R32

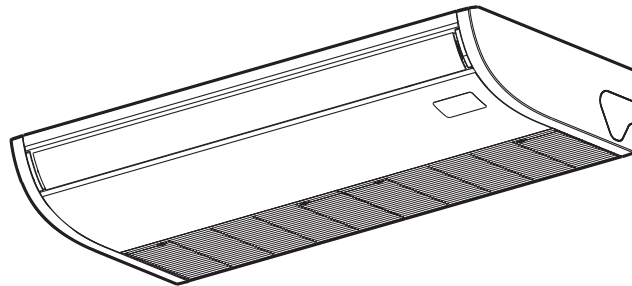

Indoor Unit

For commercial use

Model name:

Ceiling type

RAV-HM401CTP-E

RAV-HM561CTP-E

RAV-HM801CTP-E

RAV-HM901CTP-E

RAV-HM1101CTP-E

RAV-HM1401CTP-E

RAV-HM1601CTP-E

Scan QR CODE to access installation and owner's manual on website.

<https://www.toshiba-carrier.co.th/manuals/default.aspx>

Manual are available in AR/BG/CZ/DA/DE/EL/EN/ES/ET/FI/FR/
HR/HU/IT/LT/LV/NL/NO/PL/PT/RO/RU/SK/SL/SV/TR.



Original instruction









- Thank you very much for purchasing TOSHIBA Air Conditioner.
Please read this owner's manual carefully before using your Air Conditioner.
- Be sure to obtain the "Owner's manual" and "Installation manual" from constructor (or dealer).
Request to constructor or dealer
 - Please clearly explain the contents of the Owner's manual and hand over it.

Contents

1	Part names	2
2	Wired remote controller	2
3	Timer operation	5
4	Adjustment of wind direction	5
5	Maintenance	6
6	Troubleshooting	7
7	Operations and performance	8
8	Installation	9
9	Specifications	9

Information on the transportation, handling and storage of the carton

Examples of indication on the carton

Symbol	Description	Symbol	Description
	Keep dry		Do not drop
	Fragile		Do not lay down
 11 cartons	Stacking height (12 cartons can be stacked in this case)		Do not walk on this carton
	This side up		Do not step
	Handle with care		

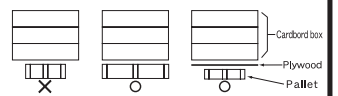
Other cautions	Description
 <div style="border: 1px solid black; padding: 5px;"> <p>Caution</p> <p>Injury possibility. Don't handle with packing band, or may get injured in case of broken band.</p> </div>	<p>CAUTION</p> <p>Injury possibility. Don't handle with packing band, or may get injured in case of broken band.</p>
<div style="border: 1px solid black; padding: 5px;"> <p>Stacking notice.</p> <p>In case that cardboard boxes protrude out of pallet when stacking, lay a 10mm thick plywood over the pallet.</p>  <p>Cardboard box Plywood Pallet</p> </div>	<p>Stacking notice.</p> <p>In case that cardboard boxes protrude out of pallet when stacking. Lay a 10 mm thick plywood over the pallet.</p>

1 Part names

■ Indoor unit

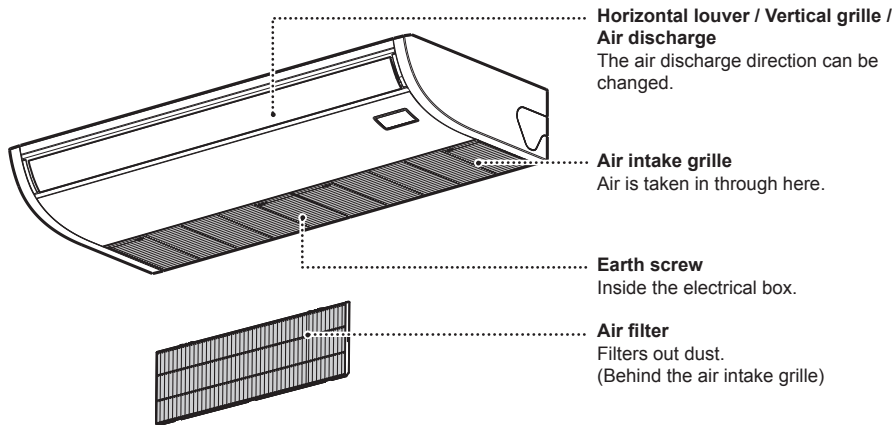

■ Outdoor unit (The design varies depending on the outdoor unit. The following illustration shows an example.)

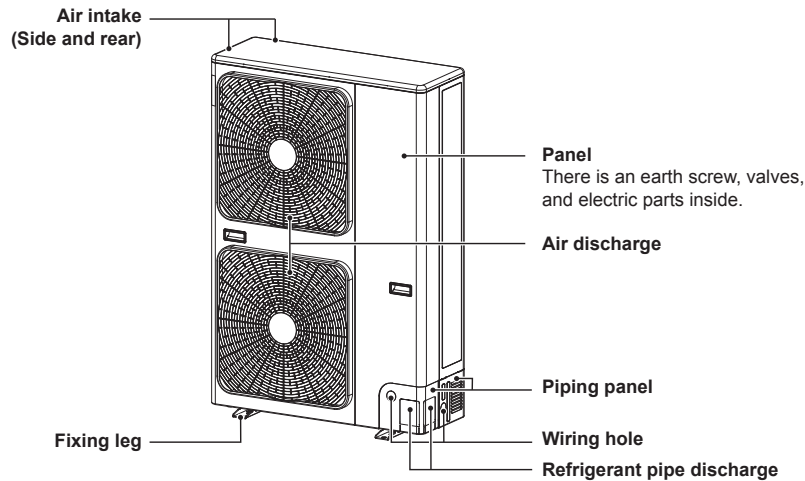

2 Wired remote controller

Remote controller model name: RBC-ASCU1*

2.1 Component Names and Functions

When operating the button, the LCD backlight will be lightened for 15 seconds.

■ Button

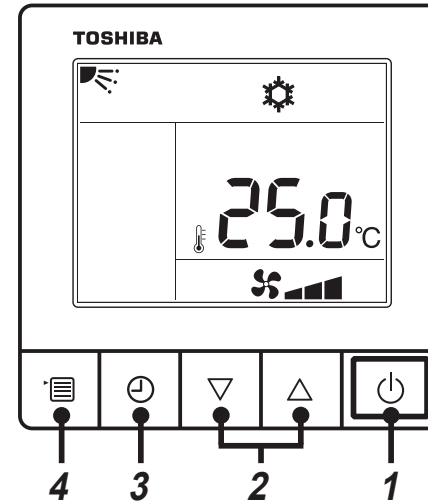

Operation lamp
Lights during operations.
Blinks when a check occurs or the protective device activates.

- 1 ON/OFF button**
Press the button to turn on the air conditioner, and press the button again to turn off the air conditioner.
- 2 Setting button**
It is used for temperature setting in general conditions. In running mode, fan speed mode and wind direction mode, it is used for the change of respective settings.
- 3 Timer off button**
Set the timer off.
- 4 Menu button**
It is used for the selection of the running mode, fan speed and wind direction. Press of the button each time, then it will switch in the following order.
 - In different modes of the indoor unit, the selection of fan speed or wind direction may be omitted.

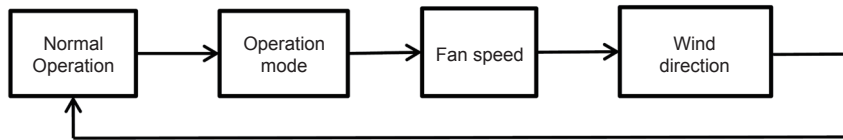

■ Indication icon

All the icons shown on the display are for illustrative purposes only. Cooling only model do not show heating-related icons. When "SETTING" flickers, the operation will not be accepted.

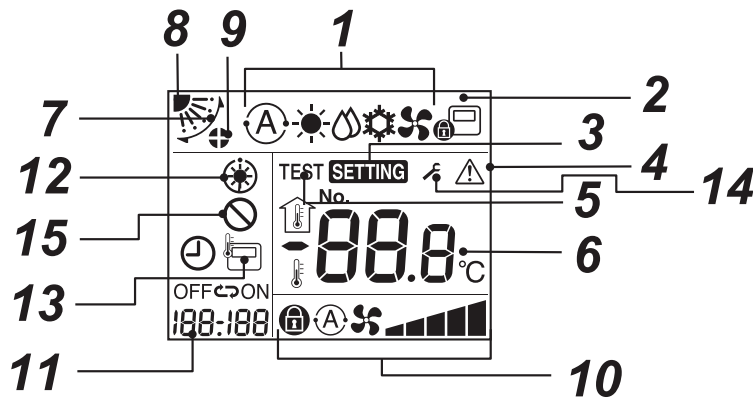

1 Running mode indication icon
Indicate the selected running mode.

2 Central control indication icon
It will be displayed when the air conditioner is centrally controlled and used by a central remote controller and other central control devices. If the central control prohibits using the remote controller,  will flash when pressing the ON/OFF, mode or temperature button on the remote controller, indicating that these buttons do not work. (The settings that can be configured on the remote controller will vary depending on the central control mode. For details, please read the Owner's Manual of the central remote controller.)

3 Setting indication icon
Indicate that the system is checking automatically after the circuit breaker has been disconnected or other conditions have occurred.

4 Repair indication icon
Display when performing an inspection or the protective device is running.

5 Test run indication icon
Display during the test run period.

6 Temperature setting indication icon
Display the selected setting temperature.

7 Wind direction indication icon
Display when the louver moves up and down.

8 Louver position indication icon
Indicate the louver position.

9 Louver locking indication icon
Display when there is a louver locking device. (4-Way cassette type only)

10 Fan speed indication icon
• Indicate the selected fan speed.



11 Timer off indication icon
When an error occurs, display the error code. In normal state, display the time of timer off

12 Pre-heat indicator
Displayed when the heating mode is energized or defrost cycle is initiated. While this indication is displayed, the indoor fan stops or operate in fan mode.

13 Remote controller sensor indication icon
Display when using the remote controller sensor.

14 Notice display
Displayed while notice code occurs. For details, contact your dealer (distributor).

15 No function display
Displayed when the function requested is not available on that model.

2.2 Operation

When you use the air conditioner for the first time or change the settings, please follow the steps below. From then on, press the On/Off button to run the air conditioner with the selected settings.

■ Standby

When "SETTING" flickers, the operation will not be accepted by system.

REQUIREMENT

- During use, keep the power switch in open state.
- When you use it again after a long time, please turn on the power switch at least 12 hours in advance.
- About 1 minute after the power is turned on, the remote controller can work. This is not a fault.

■ Run operation

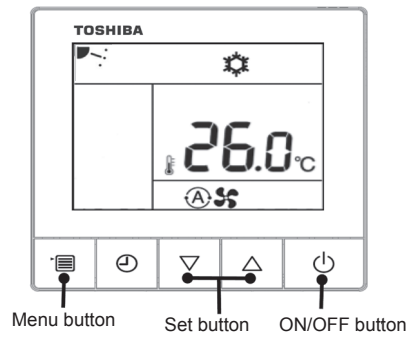

1 ON/OFF button
Press the button to light up the running indicator, and start running.

2 Select running mode
Switch to the running mode by pressing the menu button.
• The current running mode icon flickers.

Press the set button each time, then the running mode and its icons change in the following order :

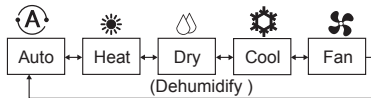

- “Dehumidify” is not available for concealed duct high static press type.
- If the button is not operated within 30 seconds, the running mode selection will end.

3 Select the fan speed
Switch to the fan speed mode by pressing the menu button.
• The current fan speed icon flickers.

Press the set button each time, then the fan speed mode and its indication change in the following order :



- The fan speed that can be set will vary depending on the connected indoor units.
- In the fan mode, “Auto” cannot be selected.
- These models that cannot set the fan speed will display “Auto”.
- If the button is not operated within 30 seconds, the fan speed selection will end.

4 Temperature selection
Press the set button to adjust the temperature.
• Temperature setting range is from 18.0°C to 29.0°C
• The sensitivity of temperature adjustment is 0.5°C.

■ 8°C operation (For object pre-heating)

The air conditioner can control the heating temperature to about 8°C in the heating mode.

The 8°C heating operation requires settings with the wired remote controller. Ask the installer or dealer for the settings according to the installation manual of the indoor unit.

Start

1. Set the displayed temperature to 18°C in the heating mode by pushing TEMP. (down arrow) button.
2. Set the displayed temperature to 8°C by pushing TEMP. (down arrow) button for at least 4 seconds

Stop

1. Set the displayed temperature to 18°C by pushing TEMP. (up arrow) button.
 - The air conditioner returns to the normal HEAT mode. Select a desired temperature and operation mode.

NOTE

- The discharged air temperature is lower than that in the normal heating operation.
- The room temperature may not be heated evenly depending on the remote controller installation location.
- The room temperature may not reach 8°C depending on the room size or the installation conditions.
- Setting for fan speed is available during the 8°C heating operation.
The 8°C heating operation is cancelled in the following cases.
 - When operation is stopped with (power) button
 - When another operation mode is selected with (list) button
 - When temperature setting or operation mode is changed or operation is started / stopped by the wireless remote controller or the central control remote controller.
- When this operation mode is used, observe proper operating hours and periodic maintenance by service staff is recommended.

3 Timer operation

3.1 Timer off Operation

Timer off: When reaching the setting time, the indoor unit stops running.

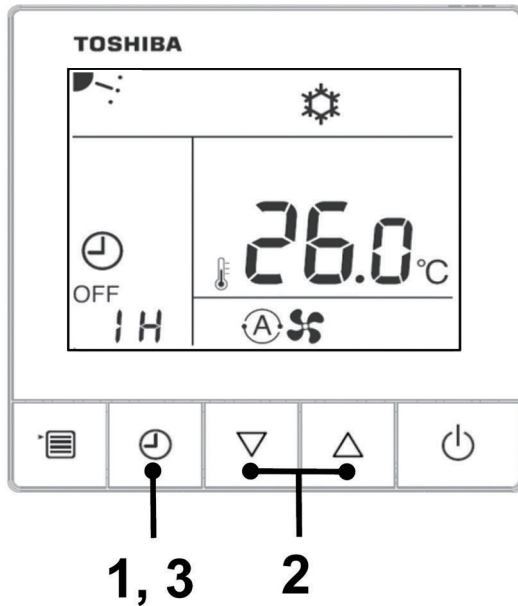

1 Timer off button

Press the timer off button in process of air conditioner operation.

- The and OFF light, while and timing indication icon flicker.

2 Select the timer off time

Press the set button to set the time.

- Increase in accordance with the law of 0.5 hour(30 minutes), 1 hour, 2 hours ..., it can be up to 24 hours.
- If you do not operate the button within 30 seconds, the timer off setting will be canceled.

3 Press the timer off button

The disappears and the timer off indication icon changes from flickering to normally on, then the timer off function starts.

When running the shutdown timer, the timing indication is displayed in the form of countdown.

■ Cancel timing

1 Press the timer off button.

The timing indication icon disappears.

NOTE

- When the shutdown timer is running, it will continue to run even if the air conditioner is turned on or off via the on/off button.

4 Adjustment of wind direction

For best cooling and heating performance, adjust the louvers (adjustment plates of up / down wind direction) appropriately. Cold air descends and warm air rises, so to heat a room tilt the louvers downward, and to cool a room tilt them horizontally.

⚠ CAUTION

Direct the louvers horizontally for cooling.
If the louvers stay pointed downward during cooling, condensation may form on the discharge port and / then drops from the louvers.

- When operation is stopped, the horizontal louver (plate for adjusting the vertical air flow) automatically closes.
- In heating preparation mode, the horizontal louver (plate for adjusting the vertical air flow) points upward. The louver starts swinging when the heating preparation mode has finished, but the swing indicator appears on the remote controller even in heating preparation mode.

As characteristics of air, cold air accumulates lower area and warm air accumulates upper area.



To set the louver direction and auto swing

- 1 Push the Menu button several times and select the wind direction mode to blink the wind direction.
- 2 Push the setting button several times to display the louver direction as shown in the figure below.
 - If you do not push any button for 30s, the wind direction mode finishes.

▼ For heating

The louver can be adjusted to six steps.

Point the louver downward. If not pointing downward, hot air may not reach the floor.

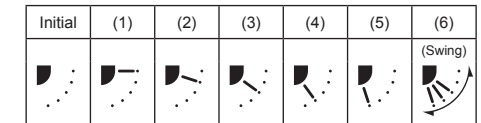

Operation mode	Available directions
HEAT, FAN	(1) ↔ (2) ↔ (3) ↔ (4) ↔ (5) ↔ (6)

▼ For cooling

The louver can be adjusted to four steps.

Point the louver horizontally. If pointing downward, dew may form on the surface of the air discharge port and may drop down.

If a louver lock setup is carried out in the position of (1), fan speed will be restricted for prevention of ceiling contamination.

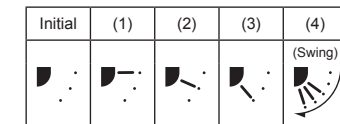

Operation mode	Available directions
COOL, DRY	(1) ↔ (2) ↔ (3) ↔ (4)

▼ For fan

The louver can be adjusted to six steps.
Select a wind direction.

■ Auto swing

The SWING  indicator is displayed and the louver begins swinging.

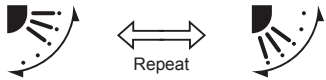

Horizontal air flow adjustment

To change the horizontal air flow direction, point the vertical louvers inside the horizontal louver in your preferred direction.

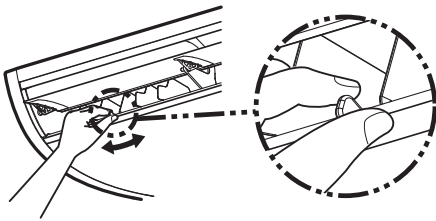

NOTE

- When the horizontal louver is pointing downward in COOL mode, water droplets may form on the surface of the cabinet or louver and drop down.
- When the horizontal louver is pointing horizontally in HEAT mode, the air may not warm up the room evenly.

5 Maintenance

 **WARNING**

Cleaning the air filter and other parts of the air filter involves dangerous work in high places, so be sure to have a qualified installer or qualified service person to do it.
Do not attempt it by yourself.

 **CAUTION**

Do not push buttons with wet hands.
Doing so may result in electric shock.

Cleaning the air filters

- When the filter indicator is displayed on the remote controller, clean the air filters.
(Only for RBC-AMTU*** and RBC-AMSU*** remote controllers.)
- Clogged filters may lower the cooling and heating performance.

When the unit will not be used for a long time

1. Perform the fan operation for a couple of hours to dry inside.
2. Stop the air conditioner with the remote controller and turn off the circuit breaker.
3. Clean the air filters and reinstall them.

Before the cooling season

Clean the drain pan

- Contact the dealer where you purchased the product.
(Drain does not work if the drain pan or vent is clogged. In some cases the drain may overflow and wet the wall or floor.
Be sure to clean the drain pan before the cooling season.)

◆ Check periodically

- If the unit is used for a long time, parts may deteriorate and cause malfunction or bad drainage of dehumidified water depending on the heat, humidity, or dust.
- In addition to the usual maintenance, it is recommended that you have the unit checked and maintained by the dealer where you purchased it.

NOTE

For environmental conservation, it is strongly recommended that the indoor and outdoor units of the air conditioner in use be cleaned and maintained regularly to ensure efficient operation of the air conditioner. When the air conditioner is operated for a long time, periodic maintenance (once a year) is recommended. Furthermore, regularly check the outdoor unit for rust and scratches, and remove them or apply rustproof treatment, if necessary.

As a general rule, when an indoor unit is operated for 8 hours or more daily, clean the indoor unit and outdoor unit at least once every 3 months. Ask a professional for this cleaning / maintenance work.

Such maintenance can extend the life of the product though it involves the owner's expense.

Failure to clean the indoor and outdoor units regularly will result in poor performance, freezing, water leakage, and even compressor failure.

Maintenance List

Part	Unit	Check (visual / auditory)	Maintenance
Heat exchanger	Indoor / outdoor	Dust / dirt clogging, scratches	Wash the heat exchanger when it is clogged.
Fan motor	Indoor / outdoor	Sound	Take appropriate measures when abnormal sound is generated.
Filter	Indoor	Dust / dirt, breakage	<ul style="list-style-type: none"> • Wash the filter with water when it is contaminated. • Replace it when it is damaged.
Fan	Indoor	<ul style="list-style-type: none"> • Vibration, balance • Dust / dirt, appearance 	<ul style="list-style-type: none"> • Replace the fan when vibration or balance is terrible. • Brush or wash the fan when it is contaminated.
Air intake / discharge grilles	Indoor / outdoor	Dust / dirt, scratches	Fix or replace them when they are deformed or damaged.
Drain pan	Indoor	Dust / dirt clogging, drain contamination	Clean the drain pan and check the downward slope for smooth drainage.
Ornamental panel, louvers	Indoor	Dust / dirt, scratches	Wash them when they are contaminated or apply repair coating.
Exterior	Outdoor	<ul style="list-style-type: none"> • Rust, peeling of insulator • Peeling / lift of coat 	Apply repair coating.

6 Troubleshooting

If there is something unusual even after checking the above, stop running the unit, turn off the circuit breaker, and inform the dealer where you purchased the product of the product number and symptom. Do not attempt to repair the unit by yourself as doing so is dangerous. If the check indicator (EQ, F01, H01, etc.) is displayed on the wired remote controller LCD, inform the dealer of its content as well.

If the air conditioner fails, the timer off indication will alternately display the check code and the number of faulted indoor unit.

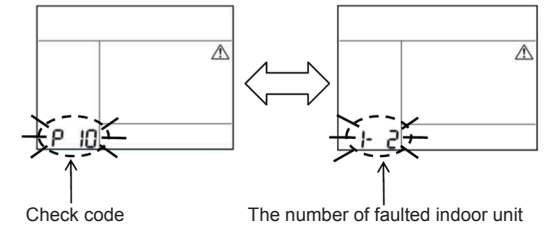

■ Troubleshooting history and confirmation

If the air conditioner fails, you can view the troubleshooting history by following the steps below. (The troubleshooting history can record at most 4 records.)

The troubleshooting history can be viewed when the air conditioner is on or off.

- If you view the troubleshooting history in the timer off operation, the timer off will be cancelled.

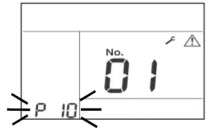
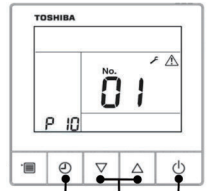
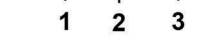
Step	Operating Instructions
1	<p>Long press the timer off button for more than 10 seconds till an indication icon appears, indicating that you have entered the troubleshooting history mode. If [Maintenance overhaul] is displayed, it indicates that you have entered the troubleshooting history mode.</p> <ul style="list-style-type: none"> • The temperature indication displays [01: Troubleshooting History Order]. • The timer off indication will alternately display [Check Code] and the faulted [Indoor Unit Number]. 
2	<p>Press the set button each time, then the recorded troubleshooting history will be displayed in the order of [01] (newest) to [04] (oldest).</p> <p>Requirements</p> <p>In the troubleshooting history mode, do not press the menu button for more than 10 seconds. Otherwise, all troubleshooting history of the indoor unit will be deleted.</p> 
3	<p>After completing the check, press the ON/OFF button to return to normal mode.</p> <ul style="list-style-type: none"> • It will continue to run if in the running mode. Please press the On/ Off button again if in the stop mode. 

7 Operations and performance

▼ Check before running

- Check whether the earth wire is cut or disconnected.
- Check whether the air filter is installed.
- Turn on the circuit breaker 12 hours or more before starting operation.

▼ 3 minutes protection function

3-minutes protection function prevents the air conditioner from starting for initial 3 minutes after the main power switch / circuit breaker is turned on for restarting the air conditioner.

▼ Power failure

Power failure during operation will stop the unit completely.

- To restart the operation, push the ON / OFF button on the remote controller.
- Lightning or a wireless car telephone operating nearby may cause the unit to malfunction. Turn off the main power switch or circuit breaker and then turn them on again. Push the ON / OFF button on the remote controller to restart.

▼ Defrosting operation

If the outdoor unit is frosted during the heating operation, defrosting starts automatically (for approximately 2 to 10 minutes) to maintain the heating capacity.

- The fans in both indoor and outdoor units will stop during the defrosting operation.
- During the defrosting operation, the defrosted water will be drained from the bottom plate of the outdoor unit.

▼ Heating capacity

In the heating operation, the heat is absorbed from the outside and brought into the room. This way of heating is called heat pump system. When the outside temperature is too low, it is recommended to use another heating apparatus in combination with the air conditioner.

▼ Protective device

- Stops operation when the air-conditioner is overloaded.
- If the protective device is activated, the unit stops running, and the operation indicator and check indicator on the remote controller blink.

▼ If the protective device is activated

- Turn off the circuit breaker and perform a checkup. Continued running may cause a malfunction.
- Check whether the air filter is installed. If not, the heat exchanger may be clogged with dust and water leakage may occur.

▼ During cooling

- The air intake or discharge of the outdoor unit is clogged.
- Strong wind continuously blows against the discharge of the outdoor unit.

▼ During heating

- The air filter is clogged with a large amount of dust.
- The air intake or discharge of the indoor unit is clogged.

▼ Do not turn off the circuit breaker

- During the air-conditioning season, leave the circuit breaker turned on, and use the ON / OFF key on the remote controller.

▼ Attention to snowfall and freeze on the outdoor unit

- In snowy areas, the air intake and air discharge of the outdoor unit are often covered with snow or frozen up. If snow or freeze on the outdoor unit is left as it is, it may cause machine failure or poor warming.
- In cold areas, pay attention to the drain hose so that it perfectly drains water without water remaining inside for freeze prevention. If water freezes in the drain hose or inside the outdoor unit, it may cause machine failure or poor warming.

▼ Air conditioner operating conditions

For proper performance, operate the air conditioner under the following temperature conditions

Cooling operation	Outdoor temperature : -15°C to 46°C (Dry bulb temp.)
	Room temperature : 21°C to 32°C (Dry bulb temp.), 15°C to 24°C (Wet bulb temp.)
	[CAUTION] Room relative humidity – less than 80%. If the air conditioner operates in excess of this figure, the surface of the air conditioner may cause dewing.
Heating operation	Outdoor temperature : -15°C to 15°C (Wet bulb temp.)
	Room temperature : 15°C to 28°C (Dry bulb temp.)

If air conditioner is used outside of the above conditions, safety protection may work.

8 Installation

Do not install the air conditioner in the following places

- Do not install the air conditioner in any place within 1 m from a TV, stereo, or radio set. If the unit is installed in such place, noise transmitted from the air conditioner affects the operation of these appliances.
- Do not install the air conditioner near a high frequency appliance (sewing machine or massager for business use, etc.), otherwise the air conditioner may malfunction.
- Do not install the air conditioner in locations where iron or other metal dust is present. If iron or other metal dust adheres to or collects on the interior of the air conditioner, it may spontaneously combust and start a fire.
- Do not install the air conditioner in a humid or oily place, or in a place where steam, soot, or corrosive gas is generated.
- Do not install the air conditioner in a salty place such as seaside area.
- Do not install the air conditioner in a place where a great deal of machine oil is used.
- Do not install the air conditioner in a place where it is usually exposed to strong wind such as in seaside area.
- Do not install the air conditioner in a place where sulfurous gas generated such as in a spa.
- Do not install the air conditioner in a vessel or mobile crane.
- Do not install the air conditioner in an acidic or alkaline atmosphere (in a hot-spring area or near a chemicals factory, or in a place subject to combustion emissions). Corrosion may be generated on the aluminum fin and copper pipe of the heat exchanger.
- Do not install the air conditioner near an obstacle (air vent, lighting equipment, etc.) that disturbs discharge air. (Turbulent airflow may reduce the performance or disable devices.)
- Do not use the air conditioner for special purposes such as preserving food, precision instruments, or art objects, or where breeding animals or growing plants are kept. (This may degrade the quality of preserved materials.)
- Do not install the air conditioner over an object that must not get wet. (Condensation may drop from the indoor unit at a humidity of 80% or more or when the drain port is clogged.)
- Do not install the air conditioner in a place where an organic solvent is used.
- Do not install the air conditioner near a door or window subject to humid outside air. Condensation may form on the air conditioner.
- Do not install the air conditioner in a place where special spray is used frequently.

Be careful with noise or vibrations

- Do not install the air conditioner in a place where noise by outdoor unit or hot air from its air discharge annoys your neighbors.
- Install the air conditioner on a solid and stable foundation so that it prevents transmission of resonating, operation noise and vibration.
- If one indoor unit is operating, some sound may be audible from other indoor units that are not operating.

9 Specifications

Model	Sound pressure level (dBA)		Weight (kg)
	Cooling	Heating	
RAV-HM401CTP-E	*	*	23
RAV-HM561CTP-E	*	*	23
RAV-HM801CTP-E	*	*	29
RAV-HM901CTP-E	*	*	37
RAV-HM1101CTP-E	*	*	37
RAV-HM1401CTP-E	*	*	37
RAV-HM1601CTP-E	*	*	37

* Under 70 dBA

Product information of ecodesign requirements. (Regulation (EU) 2016/2281)
<http://ecodesign.toshiba-airconditioning.eu/en>

Declaration of Conformity

Manufacturer: Toshiba Carrier (Thailand) Co., Ltd.
144 / 9 Moo 5, Bangkadi Industrial Park, Tivanon Road, Tambol Bangkadi,
Amphur Muang, Pathumthani 12000, Thailand

TCF holder: TOSHIBA CARRIER EUROPE S.A.S
Route de Thil 01120 Montluel FRANCE

Hereby declares that the machinery described below:

Generic Denomination: Air Conditioner

Model / type: RAV-HM401CTP-E, RAV-HM1101CTP-E
RAV-HM561CTP-E, RAV-HM1401CTP-E
RAV-HM801CTP-E, RAV-HM1601CTP-E
RAV-HM901CTP-E

Commercial name: Digital Inverter Series / Super Digital Inverter Series Air Conditioner

Complies with the provisions of the Machinery Directive (Directive 2006/42/EC) and the regulations transposing into national law

Name: Masaru Takeyama
Position: GM, Quality Assurance Dept.
Date: 10 May, 2022
Place Issued: Thailand

NOTE

This declaration becomes invalid if technical or operational modifications are introduced without the manufacturer's consent.

Declaration of Conformity

Manufacturer: Toshiba Carrier (Thailand) Co., Ltd.
144 / 9 Moo 5, Bangkadi Industrial Park, Tivanon Road, Tambol Bangkadi,
Amphur Muang, Pathumthani 12000, Thailand

TCF holder: TOSHIBA CARRIER UK LTD.
Porsham Close Belliver Industrial Estate Roborough Plymouth Devon
PL6 7DB United Kingdom

Hereby declares that the machinery described below:

Generic Denomination: Air Conditioner

Model / type: RAV-HM401CTP-E, RAV-HM1101CTP-E
RAV-HM561CTP-E, RAV-HM1401CTP-E
RAV-HM801CTP-E, RAV-HM1601CTP-E
RAV-HM901CTP-E

Commercial name: Digital Inverter Series / Super Digital Inverter Series Air Conditioner

Complies with the provisions of the Supply of Machinery (Safety) Regulations 2008

Name: Masaru Takeyama
Position: GM, Quality Assurance Dept.
Date: 10 May, 2022
Place Issued: Thailand

NOTE

This declaration becomes invalid if technical or operational modifications are introduced without the manufacturer's consent.

Toshiba Carrier (Thailand) Co., Ltd.

144 / 9 Moo 5, Bangkadi Industrial Park, Tivanon Road, Tambol Bangkadi, Amphur Muang, Pathumthani 12000, Thailand